

With its distinctive combination of commercial-style performance and unrivaled customization options, the BlueStar® Nova Series offers unique options tailored to any individual style or cooking preference. Available in 1,000+ colors and finishes plus 10 metal trims, the Nova Series can be customized with integrated cooking features like griddles, charbroilers, and swing doors.

### PRODUCT FEATURES

- 30,000 BTU integrated 24" griddle
- Available with all burners or full integrated griddle, charbroiler or French top
- Extra-large convection oven with 1850° infrared broiler that can accommodate an 18" x 13" baking sheet
- Available in 1,000+ colors & finishes plus 10 metal trims
- Available with swing doors
- Handcrafted in Pennsylvania since 1880

### SPECIFICATIONS

Range Dimensions: 23.875"W x 24"D x 36.75"H  
 Oven Interiors: 20.25"W x 20"D x 15"H  
 24" Griddle Rating: 30,000 BTUs (Two 15,000 BTU burners)  
 Oven Burner Rating: 30,000 BTUs  
 Infrared Broiler Rating: 15,000 BTUs  
 Electrical Requirements: 120V, 60Hz, 15 AMPs, 1 PH  
 (Unit must be on a Non-GFI, dedicated outlet)  
 Operating Gas Pressure: NAT: 5.0" WC, LP: 10.0" WC  
 Incoming Gas Line: 1/2"  
 Installation Clearance: 0" Side Cabinet | 0" Back Wall



### MODEL CONFIGURATION

All Griddle

RNB24GV2

### BURNER CONFIGURATION

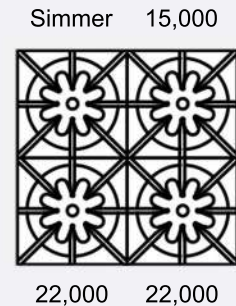

### ADDITIONAL CUSTOMIZATION OPTIONS

- Integrated 24" griddle, charbroiler or French top
- 1,000+ Colors & finishes plus 10 designer trim options
- Painted knobs
- Swing doors

*All specifications subject to change without notice.  
 Visit [www.bluestarcooking.com](http://www.bluestarcooking.com) prior to site preparation or installation.*

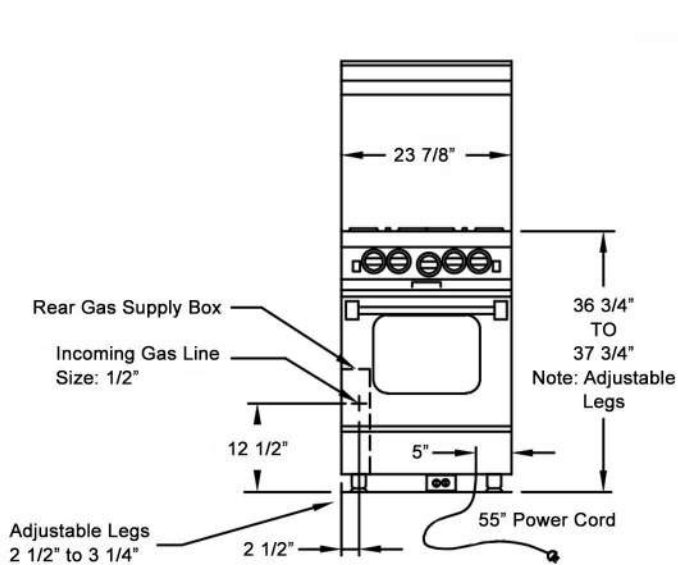

Electrical cord located in back of unit

Location of electrical outlet must not be higher than 3" from floor if located behind the unit or can be located in an adjoining cabinet.

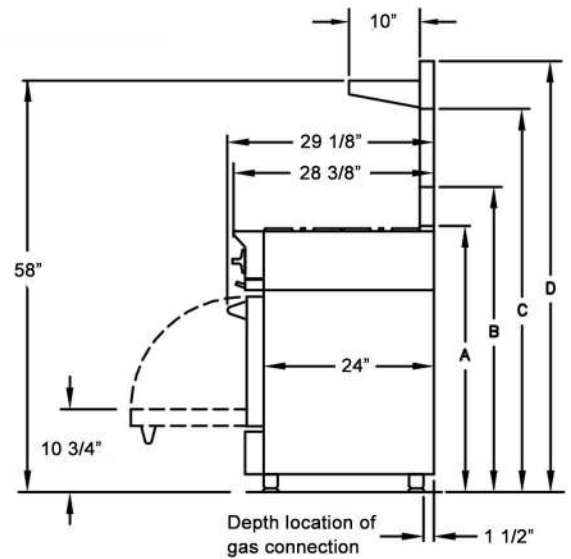

- (A) Island Trim Height 37 1/2"
- (B) 6" Backguard Height 43"
- (C) 17" Backguard Height 54"
- (D) High Shelf Height 60 3/4"

## RELATED PRODUCTS



**PRO Built-In Refrigeration**



**Designer Series Vent Hoods**

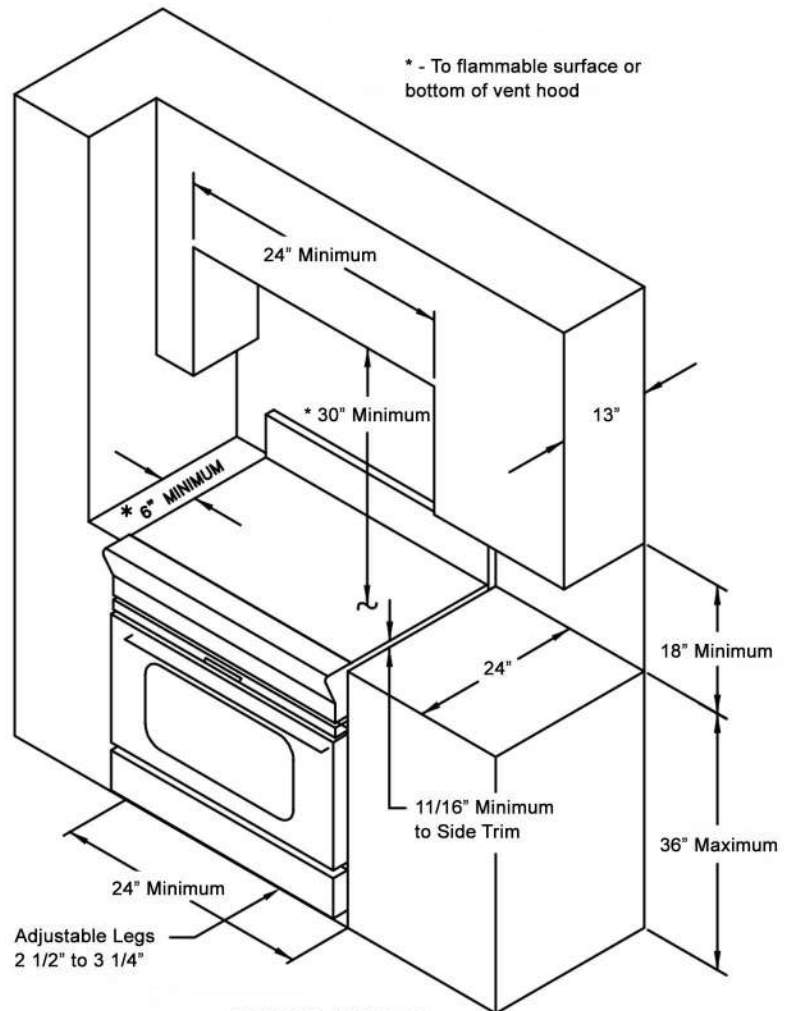

## CLEARANCES